



SMT660N

High Performance Red Color TOP LED

SMT660N consists of an AlGaInP LED mounted on the lead frame as TOP LED package and is 31mW typical of output power and 750mcd of Brightness.

It emits a spectral band of radiation at 660nm.

◆ Outer dimension (Unit: mm)

◆ Specifications

- 1) Product Name TOP IR LED
- 2) Type No. SMT660N
- 3) Chip
 - (1) Chip Material AlGaInP
 - (2) Chip Dimension 0.35mm*0.35mm
 - (3) Peak Wavelength 660nm typ.
- 4) Package
 - (1) Lead Frame Die Silver Plated
 - (2) Package Resin PPA Resin
 - (3) Lens Epoxy Resin

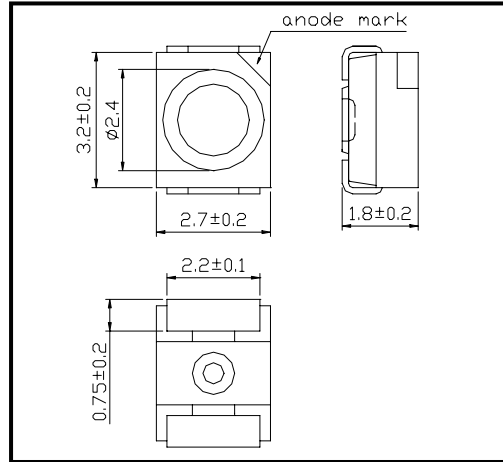

◆ Absolute Maximum Rating

Item	Symbol	Maximum Rated Value	Unit	Ambient Temperature
Power Dissipation	P _D	120	mW	T _a =25°C
Forward Current	I _F	50	mA	T _a =25°C
Reverse Voltage	V _R	5	V	T _a =25°C
Operating Temperature	T _{OPR}	-20 ~ +80	°C	
Storage Temperature	T _{STG}	-30 ~ +80	°C	
Soldering Temperature	T _{SOL}	255	°C	

‡Pulse Forward Current condition: Duty=1% and Pulse Width=10us.

‡Soldering condition: Soldering condition must be completed within 10 seconds at 255°C

◆ Electro-Optical Characteristics [T_a=25°C]

Item	Symbol	Condition	Minimum	Typical	Maximum	Unit
Forward Voltage	V _F	I _F =20mA		2.0	2.2	V
		I _F =50mA		2.2	2.4	
Total Radiated Power	P _O	I _F =20mA	9.0	12.0		mW
		I _F =50mA		31.0		
Radiant Intensity	I _E	I _F =20mA		4.0		mW/sr
		I _F =50mA		11.0		
Brightness	I _v	I _F =20mA		300		mcd
		I _F =50mA		750		
Peak Wavelength	λ _P	I _F =50mA	650	660	660	nm
Half Width	Δλ	I _F =50mA		16		nm
Viewing Half Angle	θ _{1/2}	I _F =50mA		±63		deg.

‡Total Radiated Power is measured by Photodyne #500

‡Radiant Intensity is measured by Tektronix J-6512.

USHIO EUROPE B.V. (www.ushio.eu)

Sky Park, Breguetlaan 16-18, 1438 BC, Oude Meer, The Netherlands

Tel: +31-20-4469-333 Fax: +31-20-4469-360 E-mail: led@ushio-europe.nl

◆ SMD Application
IR-Reflow Soldering Profile for lead free soldering

recommended Land Layout (Unit: mm)

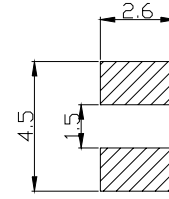
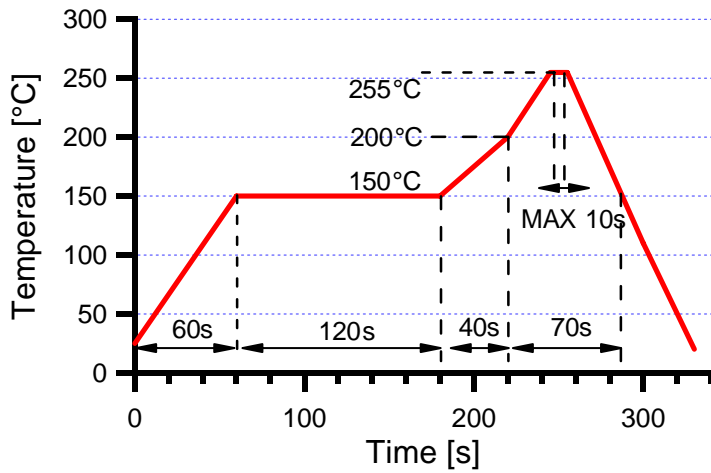

Don't put stress on SMD and a circuit board after soldering.

◆ SMD Packing
Tape and Reel Dimensions (Unit: mm)

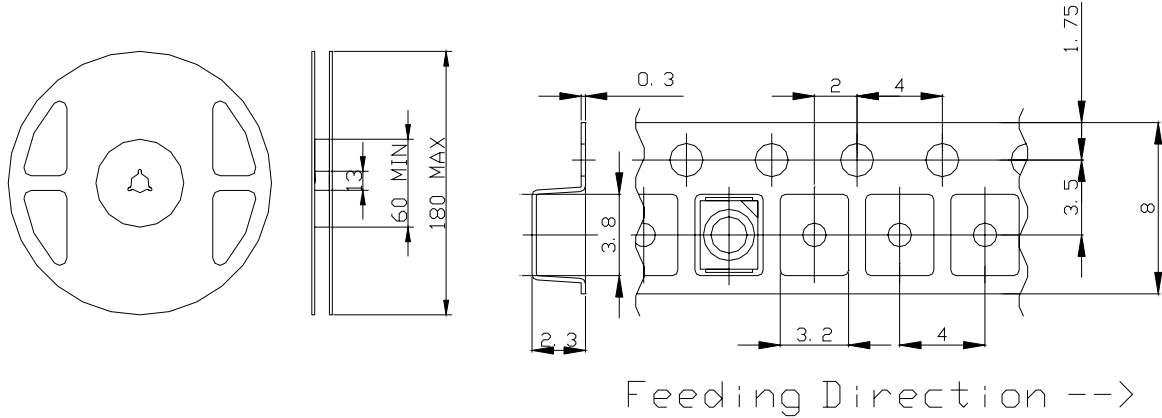

Feeding Direction -->

◆ Wrapping

Moisture barrier bag aluminum laminated film with a desiccant to keep out the moisture absorption during the transportation and storage.

SMD LED STORAGE AND HANDLING PRECAUTIONS

< Storage Conditions before Opening a Moisture-Barrier Aluminum Bag >

- Before opening a moisture-barrier aluminum bag, please store it at <30°C, <60%RH. Please note that the maximum shelf life is 12 months under these conditions.

< Storage Conditions after Opening a Moisture-Barrier Aluminum Bag >

- After opening a moisture-barrier aluminum bag, store the aluminum bag and silica gel in a desiccator.
- After opening the bag, please solder the LEDs within 72 hours in a room with 5 - 30°C, <50%RH.
- Please put any unused, remaining LEDs and silica gel back in the same aluminum bag and then vacuum-seal the bag.
- It is recommended to keep the re-sealed bag in a desiccator at <30%RH.

< Notes about Re-sealing a Moisture-Barrier Aluminum Bag >

- When vacuum-sealing an opened aluminum bag, if you find the moisture-indicator of the silica gel has changed to pink from blue (indicating a relative humidity of 30 % or more), please do not use the unused LEDs, the aluminum bag, or the silica gel.

< Notes about Opening a Re-sealed Moisture-Barrier Aluminum Bag >

- When opening a vacuumed and re-sealed aluminum bag in order to use the remaining LEDs stored in the bag, if you find that the moisture-indicator of the silica has changed to pink, please do not use the LEDs.

※The 72-hour- long floor life does not include the time while LEDs are stored in the moisture-barrier aluminum bag.
However, we strongly recommend to solder the LEDs as soon as possible after opening the aluminum bag.