

SMT660N-29

High Performance Red Color TOP LED with Lens

SMT660N-29 consists of an AlGaInP LED mounted on the lead frame as TOP LED package and is 32mW typical of output power and 1250mcd of Brightness.

It emits a spectral band of radiation at 660nm.

◆ Outer dimension (Unit: mm)

◆ Specifications

1) Product Name	TOP IR LED
2) Type No.	SMT660N-29
3) Chip	
(1) Chip Material	AlGaInP
(2) Chip Dimension	0.35mm*0.35mm
(3) Peak Wavelength	660nm typ.
4) Package	
(1) Lead Frame Die	Silver Plated
(2) Package Resin	PPA Resin
(3) Lens	Epoxy Resin

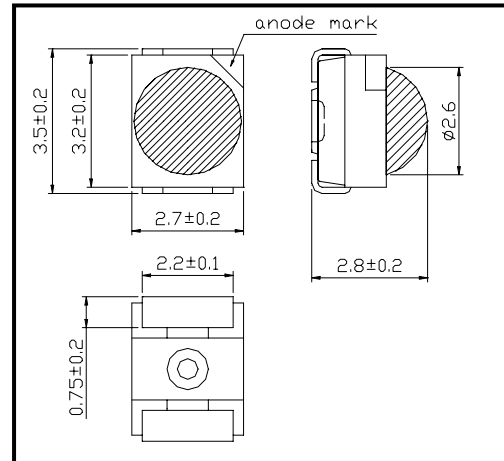

◆ Absolute Maximum Rating

Item	Symbol	Maximum Rated Value	Unit	Ambient Temperature
Power Dissipation	P _D	120	mW	T _a =25°C
Forward Current	I _F	50	mA	T _a =25°C
Reverse Voltage	V _R	5	V	T _a =25°C
Operating Temperature	T _{OPR}	-20 ~ +80	°C	
Storage Temperature	T _{STG}	-30 ~ +80	°C	
Soldering Temperature	T _{SOL}	255	°C	

‡Pulse Forward Current condition: Duty=1% and Pulse Width=10us.

‡Soldering condition: Soldering condition must be completed within 10 seconds at 255°C

◆ Electro-Optical Characteristics [T_a=25°C]

Item	Symbol	Condition	Minimum	Typical	Maximum	Unit
Forward Voltage	V _F	I _F =20mA		2.0	2.2	V
		I _F =50mA		2.2	2.4	
Total Radiated Power	P _O	I _F =20mA	9.0	12.0		mW
		I _F =50mA		32.0		
Radiant Intensity	I _E	I _F =20mA		7.0		mW/sr
		I _F =50mA		19.0		
Brightness	I _v	I _F =20mA		500		mcd
		I _F =50mA		1250		
Peak Wavelength	λ _P	I _F =50mA	650	660	660	nm
Half Width	Δλ	I _F =50mA		16		nm
Viewing Half Angle	θ _{1/2}	I _F =50mA		±42		deg.

‡Total Radiated Power is measured by Photodyne #500

‡Radiant Intensity is measured by Tektronix J-6512.

USHIO EUROPE B.V. (www.ushio.eu)

Sky Park, Breguetlaan 16-18, 1438 BC, Oude Meer, The Netherlands

Tel: +31-20-4469-333 Fax: +31-20-4469-360 E-mail: led@ushio-europe.nl

◆ SMD Application
IR-Reflow Soldering Profile for lead free soldering

Recommended Land Layout (Unit: mm)

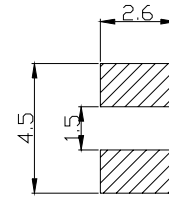
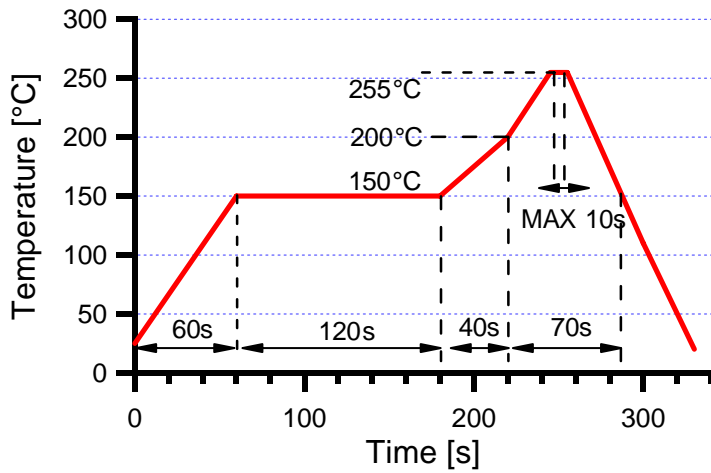

Don't put stress on SMD and a circuit board after soldering.

◆ SMD Packing
Tape and Reel Dimensions (Unit: mm)

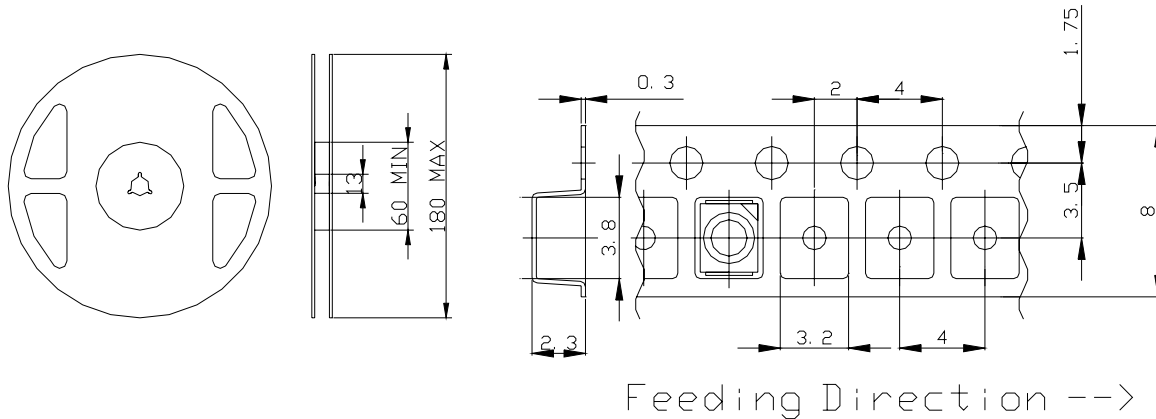

◆ Wrapping

Moisture barrier bag aluminum laminated film with a desiccant to keep out the moisture absorption during the transportation and storage.

SMD LED STORAGE AND HANDLING PRECAUTIONS

< Storage Conditions before Opening a Moisture-Barrier Aluminum Bag >

- Before opening a moisture-barrier aluminum bag, please store it at <30°C, <60%RH. Please note that the maximum shelf life is 12 months under these conditions.

< Storage Conditions after Opening a Moisture-Barrier Aluminum Bag >

- After opening a moisture-barrier aluminum bag, store the aluminum bag and silica gel in a desiccator.
- After opening the bag, please solder the LEDs within 72 hours in a room with 5 - 30°C, <50%RH.
- Please put any unused, remaining LEDs and silica gel back in the same aluminum bag and then vacuum-seal the bag.
- It is recommended to keep the re-sealed bag in a desiccator at <30%RH.

< Notes about Re-sealing a Moisture-Barrier Aluminum Bag >

- When vacuum-sealing an opened aluminum bag, if you find the moisture-indicator of the silica gel has changed to pink from blue (indicating a relative humidity of 30 % or more), please do not use the unused LEDs, the aluminum bag, or the silica gel.

< Notes about Opening a Re-sealed Moisture-Barrier Aluminum Bag >

- When opening a vacuumed and re-sealed aluminum bag in order to use the remaining LEDs stored in the bag, if you find that the moisture-indicator of the silica has changed to pink, please do not use the LEDs.

※The 72-hour- long floor life does not include the time while LEDs are stored in the moisture-barrier aluminum bag.
However, we strongly recommend to solder the LEDs as soon as possible after opening the aluminum bag.