

SMT525-21

High Performance Green color TOP LED with Lens

SMT525-21 consists of an InGaN LED mounted on the lead frame as TOP LED package with plastic ball lens and is 5.0mW typical of output power and 17,000mcd of brightness. It emits a spectral band of radiation at 525nm.

◆ Specifications

1) Product Name	TOP LED
2) Type No.	SMT525-21
3) Chip	
(1) Chip Material	InGaN
(2) Peak Wavelength	525nm typ.
4) Package	
(1) Lead Frame Die	Silver Plated
(2) Package Resin	PPA Resin
(3) Lens	Epoxy Resin
(4) Diameter	Φ2.6mm

◆ Outer dimension (Unit: mm)

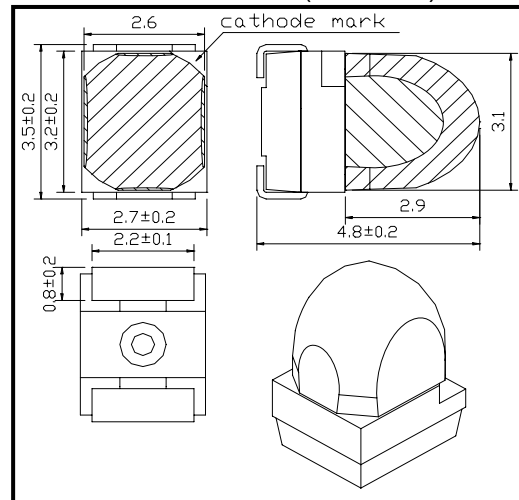

◆ Absolute Maximum Ratings

Item	Symbol	Maximum Rated Value	Unit	Ambient Temperature
Power Dissipation	P _D	120	mW	T _a =25°C
Forward Current	I _F	30	mA	T _a =25°C
Reverse Voltage	V _R	5	V	T _a =25°C
Operating Temperature	T _{OPR}	-20 ~ +80	°C	
Storage Temperature	T _{STG}	-30 ~ +80	°C	
Soldering Temperature	T _{SOL}	255	°C	

‡Soldering condition: Soldering condition must be completed within 3 seconds at 255°C

◆ Electro-Optical Characteristics [T_a=25°C]

Item	Symbol	Condition	Minimum	Typical	Maximum	Unit
Forward Voltage	V _F	I _F =20mA		3.30	4.30	V
Reverse Current	I _R	V _R =5V			10	uA
Total Radiated Power	P _O	I _F =20mA		7.5		mW
Brightness	I _V	I _F =20mA		17,000		mcd
Peak Wavelength	λ _P	I _F =20mA	515	525	535	nm
Half Width	Δλ	I _F =20mA		35		nm
Viewing Half Angle	θ _{1/2}	I _F =20mA		±4		deg.

‡Total Radiated Power is measured by Photodyne #500

‡Brightness is measured by Tektronix J-16.