

SMB870/940-2100-I

High Power type Top LED

SMB870/940-2100-I is an AlGaAs LED mounted on AlN ceramics on copper heat sink with a 5*5 mm package

◆ Specifications

- | | |
|---------------------|-------------------------|
| 1) Product Name | High Power Top LED |
| 2) Type No. | SMB870/940-2100-I |
| 3) Chip | |
| (1) Chip Material | AlGaAs |
| (2) Chip Dimension | 1000um*1000um |
| (3) Chip Number | 1pce each wavelength |
| (4) Peak Wavelength | 870nm and 940nm typ. |
| 4) Package | |
| (1) Lead Frame Die | Silver Plated on Copper |
| (2) Insulator | AlN ceramics |
| (3) Package Resin | PPA Resin |
| (4) Lens | Epoxy Resin |

◆ Outer dimension (Unit: mm)

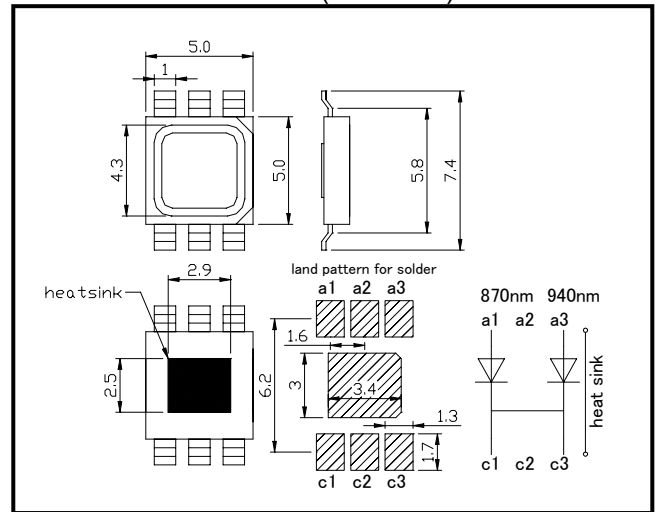

◆ Absolute Maximum Ratings

Item	Symbol	Maximum Rated Value		Unit	Ambient Temperature
		870nm	940nm		
Power Dissipation	P _D	540	420	mW	T _a =25°C
Forward Current	I _F	400	300	mA	T _a =25°C
Pulse Forward Current	I _{FP}	2000	2000	mA	T _a =25°C
Reverse Voltage	V _R	5		V	T _a =25°C
Junction Temperature	T _J	100		°C	
Thermal Resistance	R _{thja}	10		K/W	
Operating Temperature	T _{OPR}	-30 ~ +85		°C	
Storage Temperature	T _{STG}	-30 ~ +100		°C	
Soldering Temperature	T _{SOL}	255		°C	

‡Pulse Forward Current condition: Duty=1% and Pulse Width=10us.

‡Soldering condition: Soldering condition must be completed within 5 seconds at 255°C

◆ Electro-Optical Characteristics [T_a=25°C]

Item	Symbol	Condition	Minimum		Typical		Maximum		Unit
			870nm	940nm	870nm	940nm	870nm	940nm	
Forward Voltage	V _F	I _F =300mA			1.50	1.30	1.80	1.40	V
Pulsed Forward Voltage	V _{FP}	I _F =2A			2.2		3.2		V
Total Radiated Power	P _O	I _F =300mA	65	60	90	80			mW
		I _F =2A			600	530			
Radiant Intensity	I _E	I _F =300mA			35	30			mW/sr
		I _F =2A			230	200			
Peak Wavelength	λ _P	I _F =50mA	860	930	870	940	880	960	nm
Half Width	Δλ	I _F =50mA			40	50			nm
Viewing Half Angle	θ _{1/2}	I _F =50mA			±55				deg.

‡Total Radiated Power is measured by Photodyne #500

‡Brightness is measured by Tektronix J-16.

Forward Current - Forward Voltage

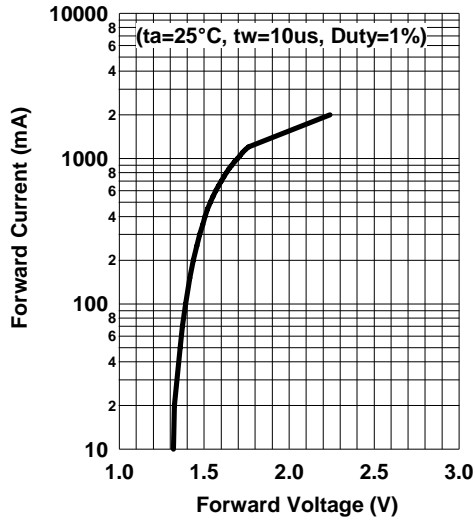

Relative Radiant Intensity - Forward Current

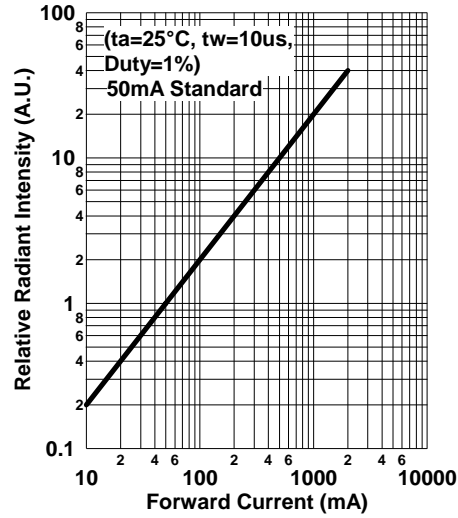

Forward Current-Pulse Duration

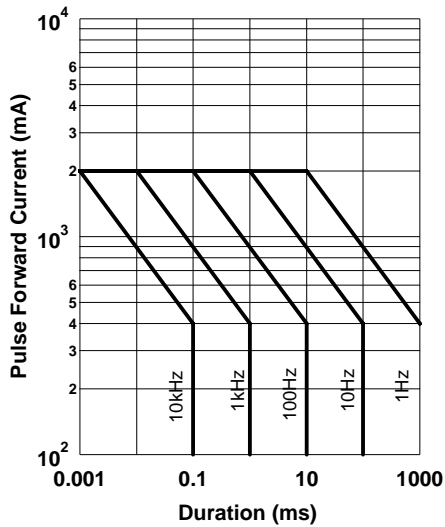

Allowable Forward Current - Ambient Temperature

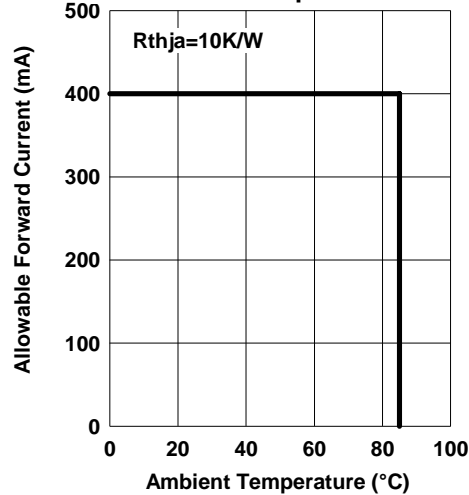

Relative Spectral Emission

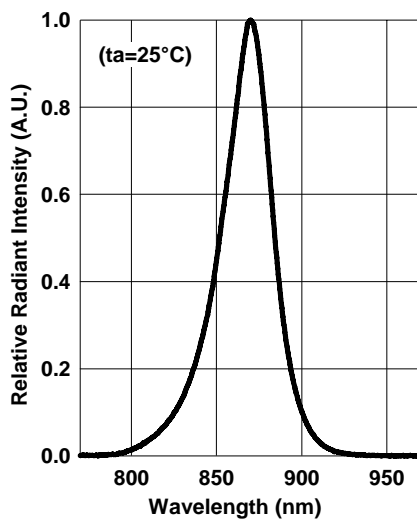

940nm Datasheet

Forward Current - Forward Voltage

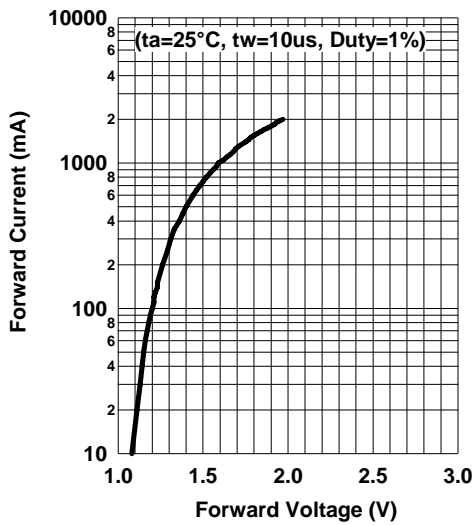

Relative Radiant Intensity - Forward Current

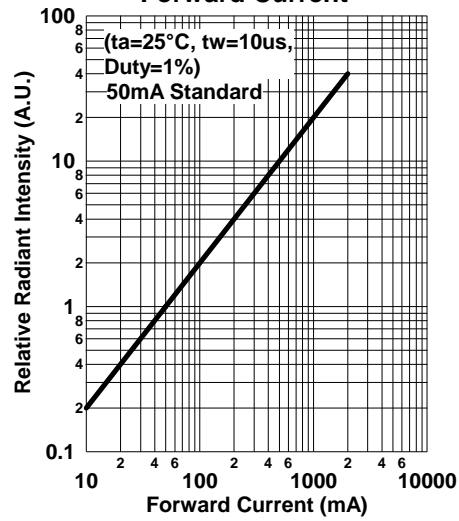

Forward Current-Pulse Duration

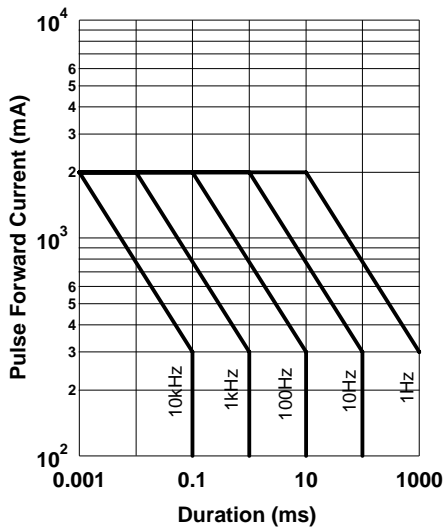

Allowable Forward Current - Ambient Temperature

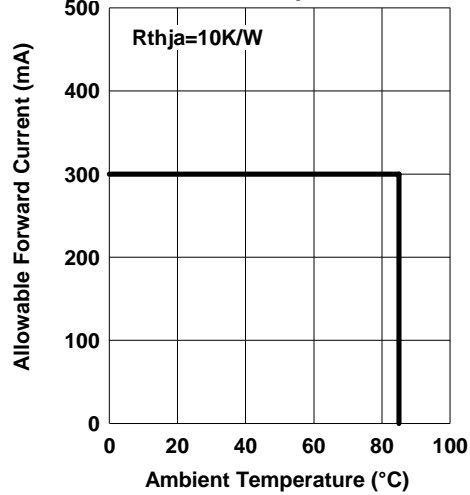

Relative Spectral Emission

