

SMB850D-1100-01

High Power type Top LED with Lens

SMB850D-1100-01 is an AlGaAs LED mounted on insulating heat sink with a 5*5 mm package with super beam epoxy resin lens and is 1800mW/sr typical of radiant intensity.

These devices are intended to be operated at pulsed current of 3A.

◆ Specifications

- | | |
|---------------------|-------------------------|
| 1) Product Name | High Power Top LED |
| 2) Type No. | SMB850D-1100-01 |
| 3) Chip | |
| (1) Chip Material | GaAlAs |
| (2) Chip Dimension | 1000um*1000um |
| (3) Chip Number | 1pce |
| (4) Peak Wavelength | 850nm typ. |
| 4) Package | |
| (1) Lead Frame Die | Silver Plated on Copper |
| (2) Package Resin | PPA Resin |
| (3) Lens | Epoxy Resin |

◆ Outer dimension (Unit: mm)

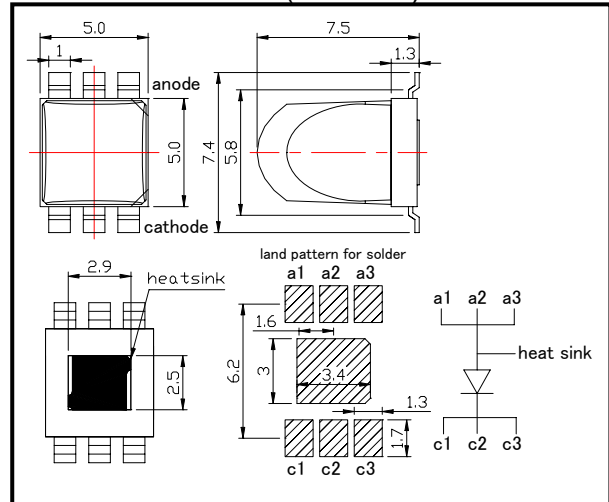

◆ Absolute Maximum Ratings

Item	Symbol	Maximum Rated Value	Unit	Ambient Temperature
Power Dissipation	P _D	3000	mW	T _a =25°C
Forward Current	I _F	1200	mA	T _a =25°C
Pulse Forward Current	I _{FP}	3000	mA	T _a =25°C
Reverse Voltage	V _R	10	V	T _a =25°C
Thermal Resistance	R _{thja}	6	K/W	
Operating Temperature	T _{OPR}	-30 ~ +85	°C	
Storage Temperature	T _{STG}	-30 ~ +100	°C	
Soldering Temperature	T _{SOL}	265	°C	

‡Pulse Forward Current condition: Duty=1% and Pulse Width=10us.

‡Soldering condition: Soldering condition must be completed within 3 seconds at 265°C

‡Thermal resistance: junction – ambient air flow

◆ Electro-Optical Characteristics [T_a=25°C]

Item	Symbol	Condition	Minimum	Typical	Maximum	Unit
Forward Voltage	V _F	I _F =1A		2.1	2.5	V
		I _F =1.2A		2.2	2.6	
Pulsed Forward Voltage	V _{FP}	I _{FP} =3A		3.5	4.5	
Reverse Current	I _R	V _R =10V			10	uA
Radiated Power	P _O	I _F =1A	400	540		mW
		I _F =1.2A		650		
Radiant Intensity	I _E	I _F =1.2A		1800		mW/sr
Peak Wavelength	λ _P	I _F =100mA		850		nm
Half Width	Δλ	I _F =100mA		20		nm
Viewing Half Angle	θ _{1/2}	I _F =100mA		±8		deg.
Rise Time	t _r	I _F =100mA		25		ns
Fall Time	t _f	I _F =100mA		15		ns

‡Radiated Power is measured by S3584-08.

‡Radiant Intensity is measured by Tektronix J-6512.