

SMB490-1100-03

High Power type Top LED with Lens

SMB490-1100-03 is an InGaN LED mounted on copper heat sink with a 5x5 mm package. These devices are available to be operated and 133,000mcd at IFP=700mA.

◆ Specifications

- | | |
|---------------------|-------------------------|
| 1) Product Name | High Power Top LED |
| 2) Type No. | SMB490-1100-03 |
| 3) Chip | |
| (1) Chip Material | InGaAs |
| (2) Chip Dimension | 1000um*1000um |
| (3) Chip Number | 1pce |
| (4) Peak Wavelength | 490nm typ. |
| 4) Package | |
| (1) Lead Frame Die | Silver Plated on Copper |
| (2) Package Resin | PPA Resin |
| (3) Lens | Epoxy Resin |

◆ Outer dimension (Unit: mm)

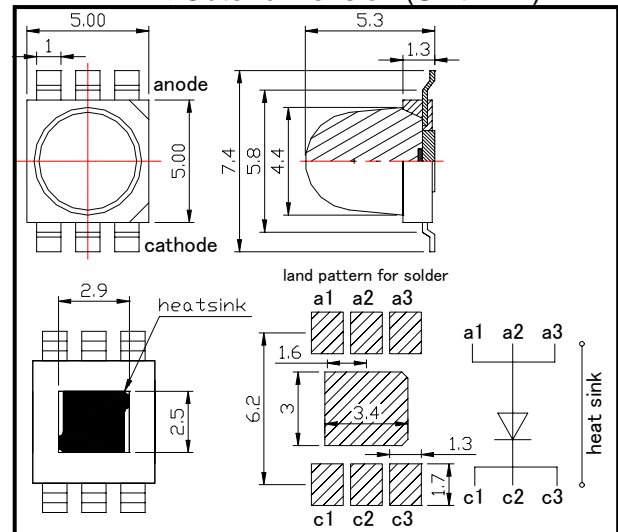

◆ Absolute Maximum Ratings

Item	Symbol	Maximum Rated Value	Unit	Ambient Temperature
Power Dissipation	PD	1400	mW	Ta=25°C
Forward Current	IF	350	mA	Ta=25°C
Pulse Forward Current	IFP	700	mA	Ta=25°C
Reverse Voltage	VR	5	V	Ta=25°C
Junction Temperature	Tj	100	°C	
Operating Temperature	TOPR	-30 ~ +85	°C	
Storage Temperature	TSTG	-30 ~ +100	°C	
Soldering Temperature	TSOL	255	°C	

‡Pulse Forward Current condition: Duty=1% and Pulse Width=10us.

‡Soldering condition: Soldering condition must be completed within 5 seconds at 255°C

◆ Electro-Optical Characteristics [Ta=25°C]

Item	Symbol	Condition	Minimum	Typical	Maximum	Unit
Forward Voltage	V _F	I _F =250mA		3.5	4.1	V
	V _{FP}	I _{FP} =700mA		4.1	4.7	
Radiated Power	P _O	I _F =250mA		160		mW
		I _{FP} =700mA		450		
Brightness	I _v	I _F =250mA		47500		mcd
		I _{FP} =700mA		133000		
Radiant Intensity	I _E	I _F =250mA		180		mW/sr
		I _{FP} =700mA		500		
Wavelength	Peak	λ _P	I _F =50mA	490		nm
	Dominant	λ _D		493		
Half Width	Δλ	I _F =50mA		27		nm
Viewing Half Angle	θ _{1/2}	I _F =50mA		±12		deg.
Rise Time	t _r	I _F =50mA		400		ns
Fall Time	t _f	I _F =50mA		40		ns

‡Radiated Power is measured by S3584-08.

‡Brightness is measured by Tektronix J-6512.

Forward Current - Forward Voltage

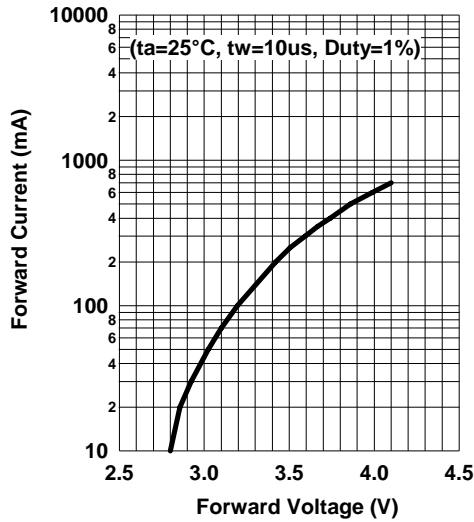

Relative Radiant Intensity - Forward Current

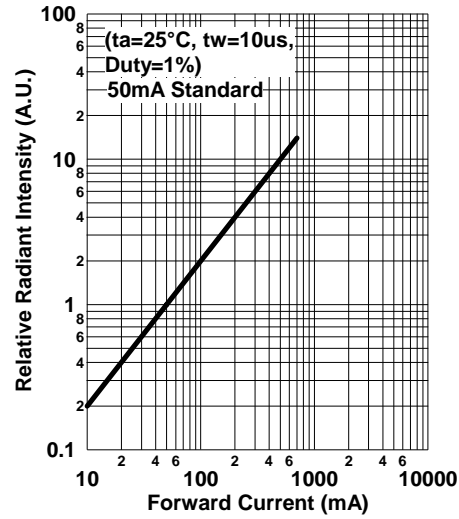

Allowable Forward Current - Ambient Temperature

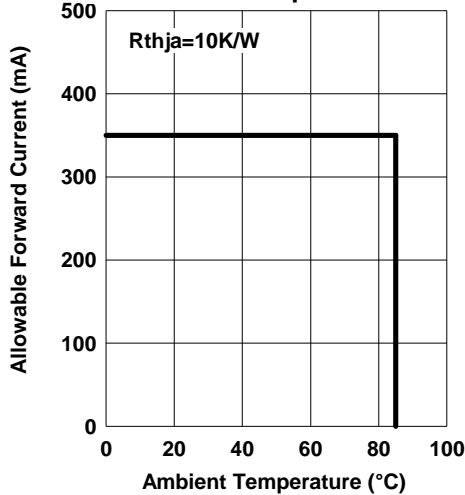

Forward Current-Pulse Duration

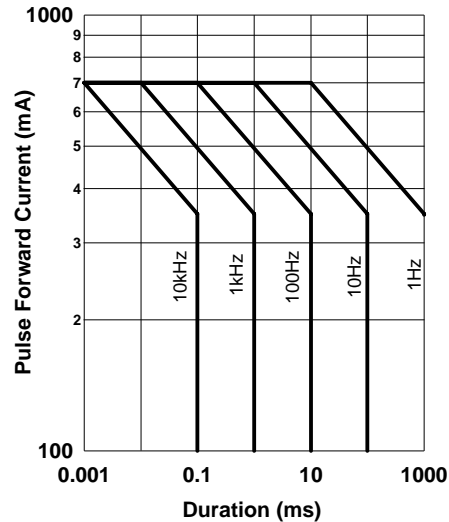

Relative Spectral Emission

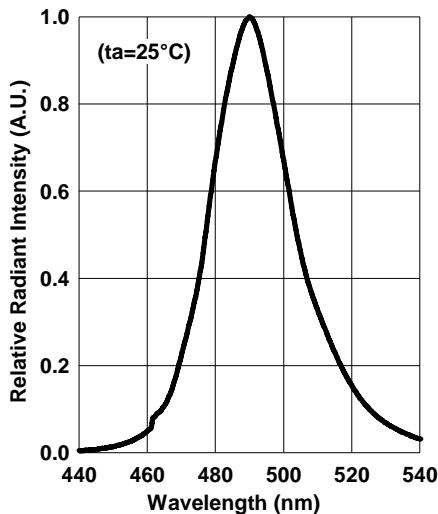

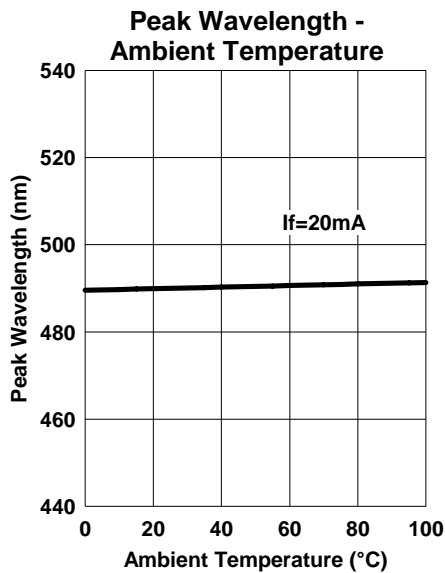
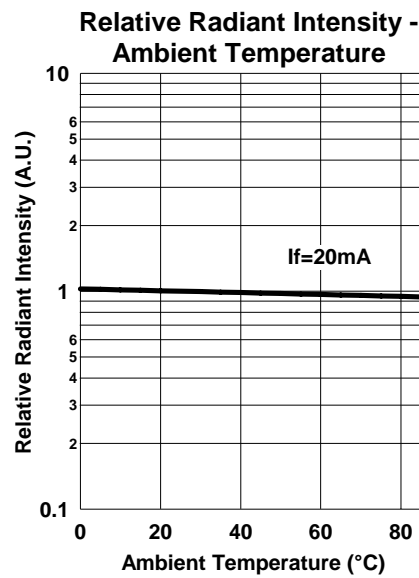
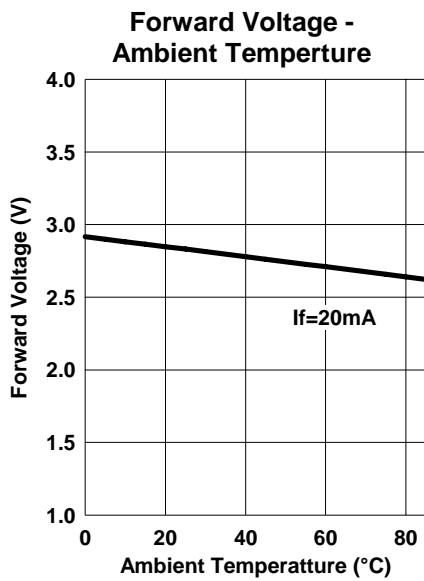

◆ Wrapping

Moisture barrier bag aluminum laminated film with a desiccant to keep out the moisture absorption during the transportation and storage.

Radiation Pattern

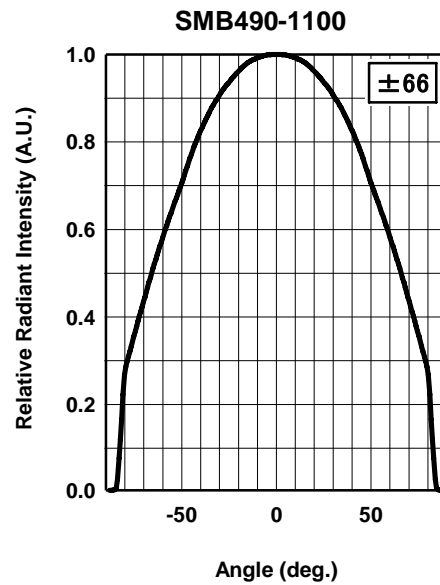
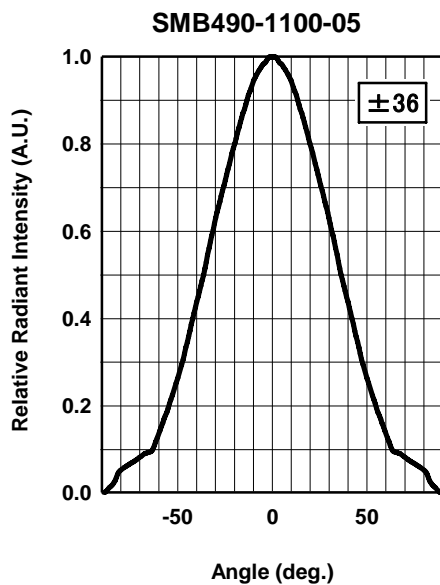
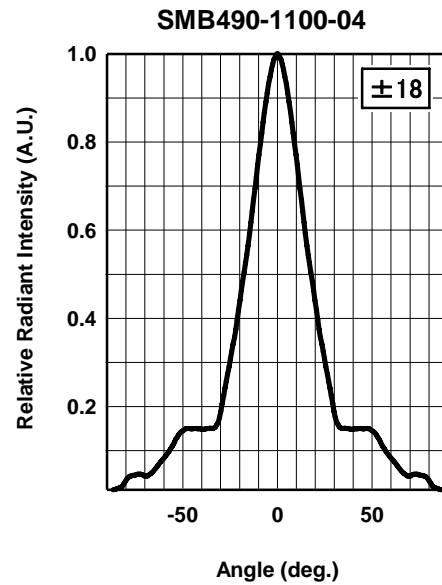
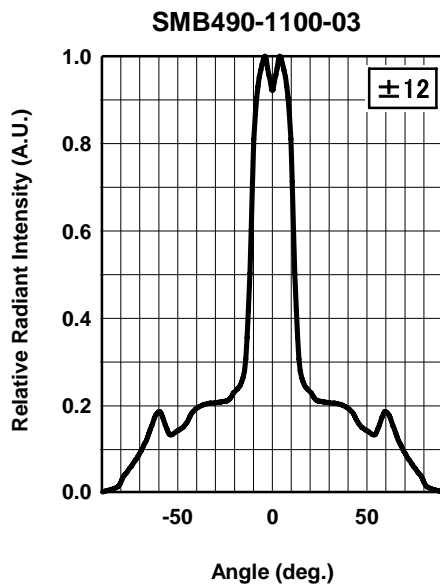
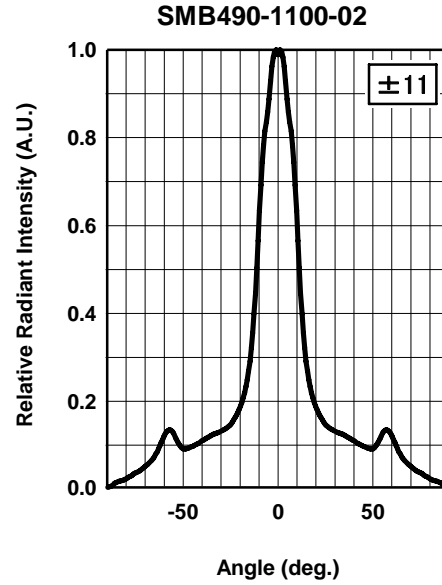
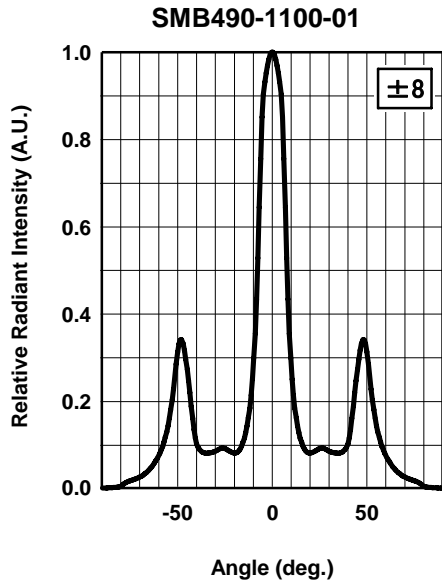

Radiation Pattern

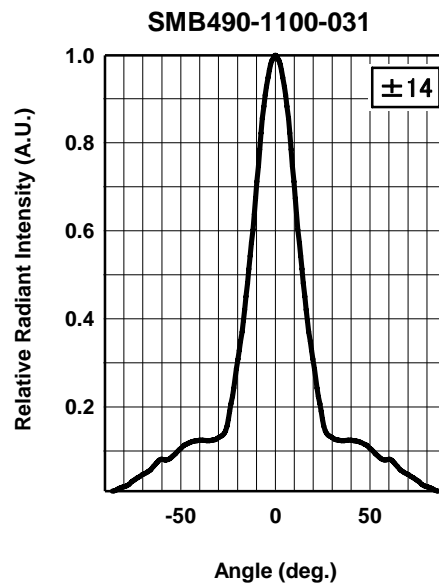
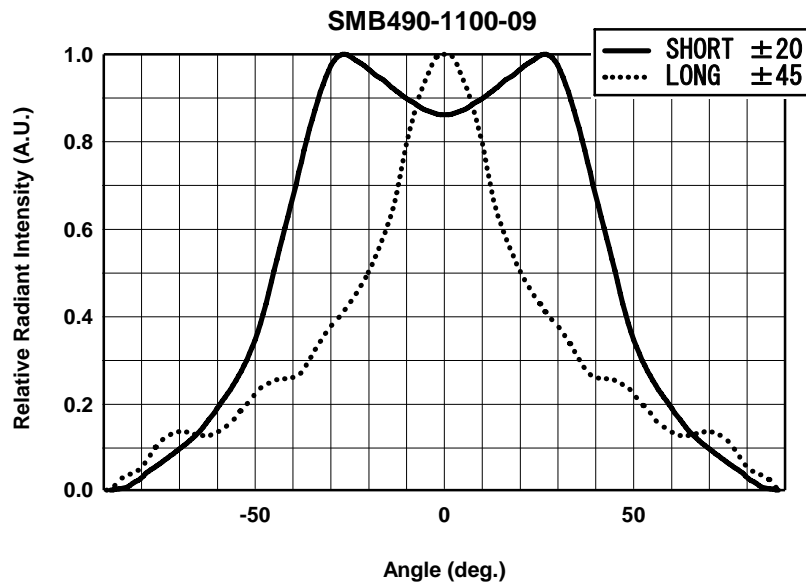

SMD LED STORAGE AND HANDLING PRECAUTIONS

< Storage Conditions before Opening a Moisture-Barrier Aluminum Bag >

- Before opening a moisture-barrier aluminum bag, please store it at <30°C, <60%RH. Please note that the maximum shelf life is 12 months under these conditions.

< Storage Conditions after Opening a Moisture-Barrier Aluminum Bag >

- After opening a moisture-barrier aluminum bag, store the aluminum bag and silica gel in a desiccator.
- After opening the bag, please solder the LEDs within 72 hours in a room with 5 - 30°C, <50%RH.
- Please put any unused, remaining LEDs and silica gel back in the same aluminum bag and then vacuum-seal the bag.
- It is recommended to keep the re-sealed bag in a desiccator at <30%RH.

< Notes about Re-sealing a Moisture-Barrier Aluminum Bag >

- When vacuum-sealing an opened aluminum bag, if you find the moisture-indicator of the silica gel has changed to pink from blue (indicating a relative humidity of 30 % or more), please do not use the unused LEDs, the aluminum bag, or the silica gel.

< Notes about Opening a Re-sealed Moisture-Barrier Aluminum Bag >

- When opening a vacuumed and re-sealed aluminum bag in order to use the remaining LEDs stored in the bag, if you find that the moisture-indicator of the silica has changed to pink, please do not use the LEDs.

※The 72-hour-long floor life does not include the time while LEDs are stored in the moisture-barrier aluminum bag.

However, we strongly recommend to solder the LEDs as soon as possible after opening the aluminum bag.